

创 导 智 能 科 技 生 活
INITIATE INTELLIGENT AND SCIENTIFIC LIFE

泰豪 **TELLHOW**

Y、YKS、YKK系列 高压笼型三相异步电动机

泰豪沈阳电机有限公司

电话: +86 (024) 25552409 (销售)
25552454 (销售)
25820928 (服务)
25823946 (传真)

邮政编码: 110142
地址: 沈阳经济技术开发区十五号街22号
网址: <http://www.symotor.com>

泰豪沈阳电机有限公司
TELLHOW SHENYANG ELECTRIC MACHINE CO.,LTD.

一、概述

Y、YKS、YKK系列中大型高压笼型三相异步电动机从H355到H1250共十二个中心高，是本公司采用国内外先进技术，通过成熟可靠的设计生产体系，结合本公司六十多年中大型高压交流电动机的制造经验而研发的新系列产品，具有效率高、噪声低、振动小、可靠性高和安装维护方便等优点。

该系列电动机功率等级、安装尺寸符合我国标准和国际电工委员会IEC标准，可用作出口设备的配套和进口产品的替代产品。

该系列电动机可用于驱动各种通用机械：如风机、水泵、压缩机及其它机械设备，广泛应用于电力、机械、矿山、冶金、石油化工等工矿企业。

二、执行标准

GB 755 旋转电机 定额和性能

GB/T 1993 旋转电机冷却方法

GB 10068 轴中心高为56mm及以上电机的机械振动 振动的测量、评定及限值

GB/T 10069.1 旋转电机噪声测定方法及限值 第1部分：旋转电机测定方法

GB 10069.3 旋转电机噪声测定方法及限值 第3部分：噪声限值

GB/T 13957 大型三相异步电动机基本系列技术条件

JB/T 7593 Y系列高压三相异步电动机技术条件（机座号355~630）

JB/T 10446 Y系列10kV三相异步电动机技术条件（机座号450~630）

JB/T 10315.1 YKS、YKS-W、YQF系列高压三相异步电动机技术条件（机座号355~630）

JB/T 10315.2 YKK、YKK-W系列高压三相异步电动机技术条件（机座号355~630）

三、基本技术参数

功率范围：185-25000kW

极数：2P-16P

额定电压：3kV-13.8kV（数据表中列出6kV和10kV参数，也可制成3kV、6.6 kV、11 kV、13.8 kV）

额定频率：50Hz、60Hz

绝缘等级：F

防护等级：IP23、IP44、IP54

冷却方式：IC01、IC81W、IC611、IC616、IC666

安装方式：IMB3

定 额：S1（工作制）

四、技术特点及结构型式

4.1 本系列电动机采用箱形结构，机座由钢板焊接成箱形，重量轻、刚度好，电机顶部安装防护顶罩或冷却器，便于电机散热，安装和维护。

4.2 定子采用外压装结构，定、转子冲片由低损耗的无取向冷轧硅钢片冲制而成。定子绕组采用F级绝缘材料，具有较强的绝缘耐压和防电晕能力，绕组端部有可靠的固定及绑扎，并采用真空压力浸渍无溶剂漆工艺（VPI）处

理，因此电动机的绝缘性能优良可靠，机械强度高，防潮能力强，使用寿命长。

4.3 转子笼条可根据性能参数或用户要求采用铸铝或铜条材质。其中铸铝笼条和端环采用离心一体铸成，保证了机械强度，防止电机运转过程中笼条断裂；铜条转子采用优质铜材，笼条通过中频焊与端环焊接，焊接质量好，强度高，并经槽内紧固工艺处理，大大减少铜条转子断条现象。

4.4 轴承采用滚动轴承和滑动轴承两种形式，由电动机功率大小和转速高低而定，其防护等级为IP44、IP54或IP55，滚动轴承设有不停机注排油装置，用户使用、维护简便。

4.5 主接线盒置于电动机右侧（从主轴伸端看），也可按用户要求置于左侧，接线盒的内外均设有单独的接地端子。

4.6 根据用户要求，可在定子绕组、轴承等重要部位加设测温装置，便于现场观察和远距离监控，以保证电动机安全可靠地运行。

五、使用条件

5.1 环境空气温度：-15℃~40℃

5.2 海拔：不超过1000m

5.3 额定频率：50Hz，允许频率偏差±2%

5.4 额定运行时，允许电压偏差±5%。（满足GB 755中7.3条件下可在±10%情况下运行）

六、型号说明

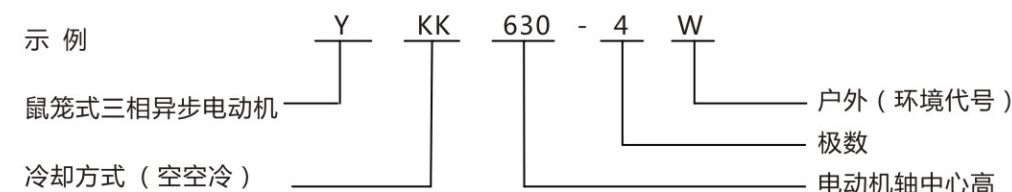

环境代号含义：

W-户外防轻腐蚀型 WF1-户外防中腐蚀型 WF2-户外防强腐蚀型

F-户内防轻腐蚀型 F1-户内防中腐蚀型 F2-户内防强腐蚀型

TH-湿热带户内型 THW-湿热带户外型 TA-干热带户内型 TAW-干热带户外型

七、订货须知

7.1 订货前，请先查阅本系列产品样本，明确所需产品型号、规格等数据。如所需品种规格与样本中有出入，请即与公司联系。

7.2 订货时须注明电动机的型号、额定功率、同步转速、额定电压、额定频率、防护等级、旋转方向、安装型式等。

7.3 样本中的技术数据和外形尺寸只作为用户选型时参考，正式资料应在合同或技术协议签订后由制造厂提供。

7.4 样本技术数据表仅列出了额定电压为6KV、10KV电机的有关数据，如果用户需要其它电压等级，制造厂也可以在订货时提供有关技术数据。

7.5 如有特殊要求，请在订货时提供数据并签订相关的技术协

八、技术数据

Y/YKS系列 (6kV) 异步电动机技术数据

型号	额定功率 (kW)	定子电流 (A)	转速 (r/min)	效率 (%)	功率因数 (cosφ)	最大转矩 额定转矩	堵转转矩 额定转矩	堵转电流 额定电流	电机转动惯量J (kg.m ²)	重量 (kg)				
										Y	YKS			
Y355-4	220	27	1480	93.3	0.85	1.8	0.8	6.5	5	1950	2450			
	250	30		93.4					6	1990	2490			
	280	34		93.5	0.86				6	2030	2530			
	315	38		93.6					6	2070	2570			
	355	42		93.8	7				2120	2620				
	400	48		94.0	7				2170	2670				
Y400-4	400	48	1483	94.0	0.87				0.8	6.5	11	2510	3010	
	450	53		94.2							12	2590	3090	
	500	59		94.3							0.87	13	2680	3180
	560	66		94.5								15	2760	3260
	630	74		94.8							15	2850	3350	
	710	83		95.0							17	2940	3440	
Y450-4	710	83	1486	95.0		0.88	0.7	6.5			28	3280	3880	
	800	93		95.1							30	3390	3990	
	900	105		95.1							33	3500	4100	
	1000	116		95.3							36	3610	4210	
	1120	128		95.4							39	3700	4320	
	1120	128		95.4							45	4510	5170	
Y500-4	1250	143	1490	95.5	0.89				0.6	6.5	49	4710	5370	
	1400	160		95.6							54	4920	5580	
	1600	181		95.7							59	5120	5780	
	1800	203		95.8							64	5320	5980	
	1800	203		95.8							80	6120	6920	
	2000	225		95.9							87	6380	7150	
Y560-4	2240	252	1487	96.0		0.89	0.6	6.5			94	6640	7380	
	2500	281		96.1							102	6900	7610	
	2500	281		96.1							125	8350	9250	
	2800	315		96.2							147	8700	9600	
	3150	354		96.3							171	9050	9950	
	3550	398		96.4							195	9400	10300	
Y630-4	3550	398	1489	96.4	0.89				0.5	6.5	220	13200	14200	
	4000	449		96.4							253	13750	14750	
	4500	505		96.4							284	14500	15500	
	5000	560		96.5							319	15200	16200	

Y/YKS系列 (6kV) 异步电动机技术数据

型号	额定功率 (kW)	定子电流 (A)	转速 (r/min)	效率 (%)	功率因数 (cosφ)	最大转矩 额定转矩	堵转转矩 额定转矩	堵转电流 额定电流	电机转动惯量J (kg.m ²)	重量 (kg)									
										Y	YKS								
Y800-4	5600	620	1491	96.5	0.9	0.5	6.5	6.5	391	18600	19800								
	6300	697		96.6					423	19300	20500								
	7100	785		96.7					460	20100	21300								
	8000	884		96.8					610	24600	26100								
Y900-4	9000	993	1489	96.9					0.91	0.5	6.5	6.5	765	25600	27100				
	10000	1102		97.0									891	26600	28100				
	11200	1220		97.1									1020	32200	34100				
Y1000-4	12500	1360	1488	97.2									0.91	0.5	6.5	6.5	1150	33600	35500
	14000	1522		97.3													1300	35000	36900
	16000	1737		97.4													1450	36400	38300
	18000	1952		97.5													1600	37800	39700
	20000	2169		97.5													1800	42400	44500
Y1120-4	22400	2429	1488	97.5	0.91	0.5	6.5	6.5									1950	44000	46100
	25000	2711		97.5													2150	45600	47700
	220	28		93.0													10	2150	2840
Y355-6	250	31	985	93.3													0.82	1.8	0.8
	280	35		93.5					12	2230	2920								
	315	39		93.7					13	2270	2960								
	315	39		93.7					17	2610	3110								
Y400-6	355	44	985	93.9					0.83	1.8	0.8	6	18	2690	3190				
	400	49		94.0									20	2770	3270				
	450	55		94.1									21	2850	3350				
	500	60		94.5									23	2930	3430				
Y450-6	500	60	989	94.5									0.84	1.8	0.8	6			
	560	67		94.7	28	3380	3980												
	630	75		94.8	30	3490	4090												
	710	85		95.0	34	3600	4200												
	800	95		95.1	39	3710	4310												
Y500-6	800	95	990	95.1	0.85	1.8	0.8	6									51	4120	4770
	900	107		95.2													57	4300	4950
	1000	119		95.3													62	4480	5130
	1120	133		95.4					68	4660	5310								
	1250	146		95.5					75	4840	5490								

Y/YKS系列 (6kV) 异步电动机技术数据

型号	额定功率 (kW)	定子电流 (A)	转速 (r/min)	效率 (%)	功率因数 (cosφ)	最大转矩 额定转矩	堵转转矩 额定转矩	堵转电流 额定电流	电机转动惯量J (kg.m ²)	重量 (kg)									
										Y	YKS								
Y560-6	1250	146	992	95.5	0.86	1.8	0.6	6.5	102	6360	7100								
	1400	164		95.6					110	6590	7330								
	1600	187		95.7					119	6820	7560								
	1800	210		95.8					129	7050	7790								
Y630-6	1800	210	991	95.8					0.86	1.8	0.6	6.5	169	7950	8850				
	2000	233		95.9									196	8300	9200				
	2240	261		96.0									223	8650	9550				
	2500	291		96.1									251	9000	9900				
Y710-6	2500	291	992	96.1									0.86	1.8	0.6	6.5	297	13900	14900
	2800	326		96.1													323	14600	15600
	3150	366		96.2													357	15300	16300
	3550	413		96.2													403	16000	17000
Y800-6	4000		994	96.3	0.86	1.8	0.6	6.5									447	16700	17700
	4500	523		96.3													520	19900	21100
	5000	580		96.4													551	20700	21900
	5600	643		96.4													583	21500	22700
Y900-6	6300	722	996	96.5					0.87	1.8	0.6	6.5					645	24900	26400
	7100	813		96.6													701	25900	27400
	8000	915		96.7													750	26900	28400
	9000	1028		96.8													1220	29660	31560
Y1000-6	10000	1141	995	96.9									0.88	1.8	0.6	6.5	1390	31060	32960
	11200	1263		97.0													1480	32460	34360
	12500	1408		97.1													1570	33860	35760
	14000	1575		97.2													2240	38750	40850
Y1120-6	16000	1798	993	97.3	0.88	1.8	0.6	6.5									2400	40350	42450
	18000	2021		97.4													2565	41950	44050
	20000	2243		97.5													2890	43550	45650
	220	29		92.9													16	2540	3040
Y400-8	250	33	740	93.0					0.80	0.8	5.5	17					2620	3120	
	280	37		93.2								18					2700	3200	
	315	41		93.4								20					2780	3280	
	355	46		93.5								22					2860	3360	
Y450-8	355	46	740	93.5								0.81	0.8	5.5	35	3110	3710		
	400	51		93.7											37	3220	3820		
	450	57		93.8											41	3330	3930		
	500	63		94.3											46	3440	4040		
	560	70		94.4	51	3550	4150												

Y/YKS系列 (6kV) 异步电动机技术数据

型号	额定功率 (kW)	定子电流 (A)	转速 (r/min)	效率 (%)	功率因数 (cosφ)	最大转矩 额定转矩	堵转转矩 额定转矩	堵转电流 额定电流	电机转动惯量J (kg.m ²)	重量 (kg)	
										Y	YKS
Y500-8	560	70	740	94.4	0.82	0.8	5.5	5.5	56	4030	4680
	630	78		94.5					61	4210	4860
	710	88		94.6					68	4390	5040
	800	97		94.7					75	4570	5220
	900	109		94.8					81	4750	5400
	900	109		94.8					113	6180	6920
Y560-8	1000	121	743	94.9	0.84	0.7	6	6	125	6410	7150
	1120	135		95.0					137	6640	7380
	1250	151		95.1					149	6870	7610
Y630-8	1250	151	992	95.1	0.85	1.8	0.6	6.5	161	7760	8660
	1400	168		95.2					174	8110	9010
	1600	192		95.3					188	8460	9360
	1800	216		95.4					202	8810	9710
	2000	240		95.5					216	9160	10060
	2000	237		95.5					321	13560	14560
Y710-8	2240	265	994	95.6	0.86	0.6	6.5	6.5	340	14260	15260
	2500	296		95.7					359	14960	15960
	2800	331		95.8					378	15660	16660
	3150	372		95.9					560	20700	21900
Y800-8	3550	419	996	96.0	0.86	0.6	6.5	6.5	582	21500	22700
	4000	466		96.1					604	22300	23500
	4500	524		96.2					750	25050	26550
Y900-8	5000	582	995	96.2	0.87	0.6	6.5	6.5	828	26050	27550
	5600	651		96.2					896	27050	28550
	6300	732		96.3					1365	30400	32300
	7100	824		96.4					1430	31800	33700
	8000	928		96.5					1516	33200	35100
	9000	1030		96.6					1620	34600	36500
Y1000-8	10000	1144	993	96.7	0.87	0.6	6.5	6.5	1739	36000	37900
	11200	1280		96.8					2530	38860	40960
	12500	1427		96.9					2689	40460	42560
	14000	1596		97.0					2890	42060	44160
	16000	1823		97.1					3069	43660	45760

Y/YKS系列 (6kV) 异步电动机技术数据

型号	额定功率 (kW)	定子电流 (A)	转速 (r/min)	效率 (%)	功率因数 (cosφ)	最大转矩 额定转矩	堵转转矩 额定转矩	堵转电流 额定电流	电机转动惯量J (kg.m ²)	重量 (kg)											
										Y	YKS										
Y450-10	220	30	591	92.1	0.77	1.8	0.8	5.5	29	2990	3590										
	250	33		92.3	0.78				31	3100	3700										
	280	37		92.5	0.79				32	3210	3810										
	315	40		92.6	0.80				34	3320	3920										
	355	47		92.8	0.82				37	3430	4030										
	400	52		93.3	0.83				41	3540	4140										
	450	58		93.4	0.84				45	3650	4250										
Y500-10	450	58	592	93.4	0.80				56	3970	4620	56	3970	4620							
	500	64		93.6	0.82				61	4150	4800	61	4150	4800							
	560	72		93.7	0.83				67	4330	4980	67	4330	4980							
	630	81		93.8	0.84				74	4510	5160	74	4510	5160							
	710	89		94.0	0.85				81	4690	5340	81	4690	5340							
	800	100		94.2	0.86				89	4870	5520	89	4870	5520							
	Y560-10	800		100	593				94.2	0.82	0.7	0.7	6	122	6000	6740					
900		112	94.3	0.83		132	6230	6970	132	6230				6970							
1000		124	94.4	0.84		143	6460	7200	143	6460				7200							
1120		139	94.6	0.85		155	6690	7430	155	6690				7430							
Y630-10		1120	139	94.6		0.86	197	7710	8610	197				7710	8610						
	1250	155	94.8	0.87	212	8060	8960	212	8060	8960											
	1400	173	94.9	0.88	229	8410	9310	229	8410	9310											
	1600	198	95.0	0.89	244	8760	9660	244	8760	9660											
Y710-10	1800	219	992	95.1	0.83	0.6	0.6	6	259	9110				10010							
	2000	244		95.2	0.84				395	14020				14990	395	14020	14990				
	2240	273		95.3	0.85				456	14690				15690	456	14690	15690				
Y800-10	2500	304	994	95.4	0.86				0.6	0.6				6	533	15390	16390				
	2800	340		95.5	0.87										630	20100	21300	630	20100	21300	
	3150	377		95.6	0.88										690	20900	22100	690	20900	22100	
Y900-10	3550	425	996	95.7	0.84						0.6	0.6	6		751	21700	22900				
	4000	478		95.8	0.85										829	25050	26550	829	25050	26550	
	4500	538		95.8	0.86										914	26050	27550	914	26050	27550	
	Y900-10	4500		538	95.8										0.87	983	27050	28550	983	27050	28550
		5000		597	95.9										0.88	1053	28050	29550	1053	28050	29550

Y/YKS系列 (6kV) 异步电动机技术数据

型号	额定功率 (kW)	定子电流 (A)	转速 (r/min)	效率 (%)	功率因数 (cosφ)	最大转矩 额定转矩	堵转转矩 额定转矩	堵转电流 额定电流	电机转动惯量J (kg.m ²)	重量 (kg)													
										Y	YKS												
Y1000-10	5600	669	995	95.9	0.84	1.8	0.8	5.5	1580	32650	34550												
	6300	752		96.0					0.85	1690	34050	35950	1690	34050	35950								
	7100	847		96.0					0.86	1850	35450	37350	1850	35450	37350								
	8000	954		96.1					0.87	2065	36850	38750	2065	36850	38750								
Y450-12	220	32	492	91.4	0.73				1.8	0.7	6	34	3170	3770									
	250	36		91.7	0.74							37	3280	3880	37	3280	3880						
	280	39		92.7	0.75							42	3390	3990	42	3390	3990						
	315	44		92.8	0.76							48	3500	4100	48	3500	4100						
Y500-12	315	44	492	92.8	0.77							1.8	0.7	6	56	3860	4510						
	355	49		93.0	0.78										61	4040	4690	61	4040	4690			
	400	55		93.3	0.79										67	4220	4870	67	4220	4870			
	450	62		93.4	0.80										74	4400	5050	74	4400	5050			
	500	65		93.7	0.81										82	4580	5230	82	4580	5230			
	560	73		93.8	0.82										90	4760	5410	90	4760	5410			
	630	82		93.9	0.83	133	6350	7090							133	6350	7090						
Y560-12	630	82	494	93.9	0.84	1.8	0.7	6							143	6580	7320						
	710	92		94.0	0.85										155	6810	7550	155	6810	7550			
	800	103		94.2	0.86										167	7040	7780	167	7040	7780			
	800	103		94.2	0.87				197	7560	8460				197	7560	8460						
Y630-12	900	116	495	94.3	0.88				1.8	0.7	6				212	7910	8810						
	1000	129		94.4	0.89										241	8260	9160	241	8260	9160			
	1120	144		94.5	0.90										261	8610	9510	261	8610	9510			
	1250	161		94.6	0.91							282	8960	9860	282	8960	9860						
Y710-12	1250	161	494	94.6	0.92							1.8	0.7	6	345	13580	14580						
	1400	180		94.7	0.93										364	14280	15280	364	14280	15280			
	1600	203		94.7	0.94										383	14980	15980	383	14980	15980			
	1800	228		94.8	0.95										403	15680	16680	403	15680	16680			
Y800-12	2000	253	496	94.9	0.96										1.8	0.7	6	650	20050	21250			
	2240	284		95.0	0.97													679	20850	22050	679	20850	22050
	2500	312		95.2	0.98	700	21650	22850										700	21650	22850			
Y900-12	2800	349	495	95.3	0.99	1.8	0.7	6										1065	24450	25950			
	3150	392		95.4	1.00													1126	25450	26950	1126	25450	26950
	3550	442		95.5	1.01													1220	26450	27950	1220	26450	27950
Y1000-12	4000	497	495	95.6	1.02				1.8	0.6	6							1750	28260	30160			
	4500	559		95.6	1.03													1895	29660	31560	1895	29660	31560
	5000	621		95.7	1.04													2050	31060	32960	2050	31060	32960
	Y1000-12	5000		621	95.7													1.05	2210	32460	34360	2210	32460
		5600		695	95.7							1.06											

Y/YKS系列 (10kV) 异步电动机技术数据

型号	额定功率 (kW)	定子电流 (A)	转速 (r/min)	效率 (%)	功率因数 (cosφ)	最大转矩 额定转矩	堵转转矩 额定转矩	堵转电流 额定电流	电机转动惯量J (kg.m ²)	重量 (kg)				
										Y	YKS			
Y400-4	220	15	1480	92.5	0.85	1.8	0.7	7	10	2400	2850			
	250	17		92.7					11	2470	2920			
	280	19		92.9					12	2540	2990			
	315	22		93.1					13	2610	3060			
	355	25		93.3					14	2680	3130			
	400	28		93.5					15	2750	3200			
	450	31		93.9					16	2820	3270			
Y450-4	450	31	1484	93.9	0.86	1.8	0.7	7	17	3120	3720			
	500	35		94.0					19	3730	3830			
	560	39		94.2					21	3340	3940			
	630	44		94.4					22	3450	4050			
	710	49		95.0					24	3560	4160			
Y500-4	800	55	1489	95.1	0.88				1.8	0.7	7	26	3670	4270
	900	61		95.2								42	4130	4780
	1000	68		95.3		44	4310	4960						
	1120	76		95.4		49	4490	5140						
	1250	84		95.5		51	4670	5320						
Y560-4	1400	94	1490	95.7	0.89	1.8	0.6	7				53	4850	5500
	1400	94		95.7								57	5030	5680
	1600	107		95.8					70	5610	6350			
	1800	121		95.9					75	5840	6580			
	2000	134		96.0					80	6070	6810			
Y630-4	2000	134	1490	96.0	0.89				1.8	0.6	7	85	6300	7040
	2240	150		96.1								119	8440	9340
	2500	168		96.1		127	8790	9690						
	2800	188		96.1		143	9140	10040						
	3150	212		96.1		159	9490	10390						
Y710-4	3150	212	1492	96.1	0.86	1.8	0.5	6.5				176	9840	10740
	3550	239		96.1								186	13600	14600
	4000	269		96.2					196	14300	15300			
	4500	302		96.2					207	15000	16000			
	4500	302		96.2					217	15700	16700			
Y800-4	5000	336	1492	96.3	0.86				1.8	0.5	6.5	295	17700	18900
	5600	376		96.3								325	18500	19700
	6300	423		96.4		356	19300	20500						
						387	20100	21300						

Y/YKS系列 (10kV) 异步电动机技术数据

型号	额定功率 (kW)	定子电流 (A)	转速 (r/min)	效率 (%)	功率因数 (cosφ)	最大转矩 额定转矩	堵转转矩 额定转矩	堵转电流 额定电流	电机转动惯量J (kg.m ²)	重量 (kg)				
										Y	YKS			
Y900-4	6300	423	1492	96.4	0.89	1.8	0.5	6.5	489	22800	24300			
	7100	476		96.5					529	23800	25300			
	8000	536		96.6					568	24800	26300			
	9000	603		96.7					607	25800	27300			
	9000	603		96.7					877	33200	35100			
Y1000-4	10000	669	1492	96.8	0.89	1.8	0.5	6.5	958	34600	36500			
	11200	749		96.9					1038	36000	37900			
	12500	835		97.0					1117	37400	39300			
	14000	934		97.1					1199	38800	40700			
	14000	934		97.1					1199	38800	40700			
Y400-6	220	16	985	92.2	0.82	1.8	0.7	6	12	2430	2880			
	250	18		92.4					14	2500	2950			
	280	20		92.6					16	2570	3020			
	315	23		92.8					18	2640	3090			
Y450-6	315	24	990	92.8	0.83				1.8	0.7	6	20	2890	3490
	355	27		93.1								22	3000	3600
	400	30		93.3								24	3110	3710
	450	33		93.5		26	3220	3820						
	500	37		93.9		28	3330	3930						
Y500-6	560	41	991	94.1	0.84	1.8	0.7	6				30	3440	4040
	560	41		94.1								45	4120	4770
	630	46		94.4					50	4300	4950			
	710	52		94.6					55	4480	5130			
	800	58		94.7					60	4660	5310			
Y560-6	900	64	993	94.9	0.85				1.8	0.6	6	66	4840	5490
	1000	71		95.1								72	5020	5670
	1000	38		95.1		80	5580	6320						
	1120	79		95.3		90	5810	6550						
	1250	88		95.4		100	6040	6780						
Y630-6	1400	98	995	95.7	0.86	1.8	0.6	6				110	6270	7010
	1600	112		95.8								121	6500	7240
	1600	112		95.8					168	8160	9060			
	1800	126		95.9					182	8510	9410			
	2000	140		95.9					195	8860	9760			
	2240	157	995	95.9	0.86				1.8	0.6	6	208	9210	10110
	2500	175		95.9								221	9560	10460

Y/YKS系列 (10kV) 异步电动机技术数据

型号	额定功率 (kW)	定子电流 (A)	转速 (r/min)	效率 (%)	功率因数 (cosφ)	最大转矩 额定转矩	堵转转矩 额定转矩	堵转电流 额定电流	电机转动惯量J (kg.m ²)	重量 (kg)	
										Y	YKS
Y710-6	2500	175	993	95.9	0.86	1.8	0.6	6.5	328	13700	14700
	2800	196		95.9					353	14400	15400
	3150	221		95.9					387	15100	16100
	3550	248		96.0					405	15800	16800
Y800-6	3550	248		96.0					530	18500	19700
	4000	279		96.1					550	19300	20500
	4500	314		96.1					575	20100	21300
Y900-6	5000	349		96.2					601	20900	22100
	5600	386		96.2					740	23200	24700
	6300	434		96.3					781	24200	25700
Y1000-6	7100	489		96.4					822	25200	26700
	8000	550		96.5					853	26200	27700
	9000	618	96.6	1110	27260	29160					
	10000	686	96.7	1225	28660	30560					
Y450-8	220	18	740	92.2	0.76	1.8	0.7	6	23	2690	3290
	250	21		92.4					27	2800	3400
	280	23		92.6					29	2910	3510
	315	25		92.8					31	3020	3620
	355	29		93.1					33	3130	3730
Y500-8	355	29		93.1					45	3730	4380
	400	32		93.2					47	3910	4560
	450	36		93.4					51	4090	4740
	500	39		93.8					53	4270	4920
Y560-8	560	44		93.9					58	4450	5100
	630	47		94.4					61	4630	5280
	710	53		94.6					65	4810	5460
	710	53	94.6	80	5680	6420					
Y560-8	800	59	94.7	90	5910	6650					
	900	67	94.8	100	6140	6880					
	1000	73	95.0	110	6370	7110					
	1120	82	95.2	120	6600	7340					

Y/YKS系列 (10kV) 异步电动机技术数据

型号	额定功率 (kW)	定子电流 (A)	转速 (r/min)	效率 (%)	功率因数 (cosφ)	最大转矩 额定转矩	堵转转矩 额定转矩	堵转电流 额定电流	电机转动惯量J (kg.m ²)	重量 (kg)							
										Y	YKS						
Y630-8	1120	82	745	95.2	0.83	1.8	0.7	6	147	8280	9180						
	1250	91		95.3					161	8630	9530						
	1400	101		95.3					181	8980	9880						
	1600	115		95.3					199	9330	10230						
	1800	130		95.3					222	9680	10580						
	Y710-8	1800		130					743	95.3	0.84	1.8	0.6	6.5	339	13050	14050
2000		143	95.3	356	13750	14750											
2240		160	95.3	391	14450	15450											
Y800-8	2500	178	95.4	408	15150	16150											
	2800	199	95.5	460	18400	19600											
	3150	224	95.6	510	19200	20400											
	3550	252	95.7	565	20000	21200											
Y900-8	3550	252	95.7	615	20800	22000											
	4000	280	95.8	750	23350	24850											
	4500	315	95.9	830	24350	25850											
Y1000-8	5000	350	746	96.0	0.86	1.8	0.6	6.5		915					25350	26850	
	5600	391		96.1						999					26350	27850	
	6300	440		96.2					1250	28200	30100						
	7100	495		96.3					1320	29600	31500						
	8000	557		96.4					1400	31000	32900						
	9000	619		96.5					1491	32400	34300						
	Y450-10	220		19					591	92.0	0.73	1.8	0.7	5.5	38	3190	3790
		250		21						92.2					41	3300	3900
Y500-10	280	24		92.4						50					3770	4420	
	315	27		92.6						53					3950	4600	
	355	29		92.8						58					4130	4780	
	400	33		93.0						62					4310	4960	
	450	36	93.2	65	4490	5140											
Y560-10	500	40	93.4	69	4670	5320											

Y/YKS系列 (10kV) 异步电动机技术数据

型号	额定功率 (kW)	定子电流 (A)	转速 (r/min)	效率 (%)	功率因数 (cosφ)	最大转矩 额定转矩	堵转转矩 额定转矩	堵转电流 额定电流	电机转动惯量J (kg.m ²)	重量 (kg)									
										Y	YKS								
Y560-10	500	40	593	93.4	0.77	1.8	0.7	6	90	5610	6350								
	560	44		93.5					100	5840	6580								
	630	50		93.7	112				6070	6810									
	710	56		93.9	121				6300	7040									
	800	61		94.3	132				6530	7270									
	900	69		94.5	143				6760	7500									
Y630-10	900	69	592	94.5	0.80				1.8	0.7	6	154	7850	8750					
	1000	76		94.6								171	8200	9100					
	1120	85		94.7	188							8550	9450						
	1400	105		94.7	209							8900	9800						
	1600	120		94.7	237							9250	10150						
Y710-10	1600	120	596	94.7	0.82							1.8	0.6	6	576	13890	14890		
	1800	134		94.8		620	14590	15590											
	2000	148		94.9		678	15290	16290											
	2000	148		94.9		701	19200	20400											
Y800-10	2240	166	593	95.0		0.83	1.8	0.6							6	766	20020	21200	
	2500	185		95.1												826	21200	22000	
	2800	207		95.2												890	22030	22800	
	2800	207		95.2					930	24050	25550								
Y900-10	3150	230	596	95.3					0.83	1.8	0.6					6	1010	25050	26550
	3550	259		95.4													1090	26050	27550
	4000	291		95.5													1175	27050	28550
	4000	291		95.5													1360	29900	31800
Y1000-10	4500	327	495	95.6	0.71							1.8	0.6	6			1410	31300	33200
	5000	363		95.7													1560	32700	34600
	5600	407		95.8													1710	34100	36100
	6300	457		95.9													1860	35500	37400
	7100	514		96.0		2012	36900	38800											
	220	19		91.8		56	3420	4070											
Y500-12	250	22	495	91.9		0.72	0.7	5.5							6		65	3600	4250
	280	24		92.1													70	3780	4430
	315	27		92.3		75			3960	4610									
	355	30		92.5		80			4140	4790									

Y/YKS系列 (10kV) 异步电动机技术数据

型号	额定功率 (kW)	定子电流 (A)	转速 (r/min)	效率 (%)	功率因数 (cosφ)	最大转矩 额定转矩	堵转转矩 额定转矩	堵转电流 额定电流	电机转动惯量J (kg.m ²)	重量 (kg)									
										Y	YKS								
Y560-12	355	30	493	92.5	0.73	1.8	0.7	6	100	5730	6470								
	400	34		92.7					110	5960	6700								
	450	38		92.9	120				6190	6930									
	500	42		93.2	130				6420	7160									
	560	47		93.5	140				6650	7390									
	630	52		93.7	150				6880	7620									
Y630-12	630	52	495	93.7	0.74				1.8	0.6	6	161	7730	8630					
	710	59		93.9								172	8080	8980					
	800	66		94.3	183							8430	9330						
	900	73		94.3	194							8780	9680						
	1000	82		94.3	205							9130	10030						
Y710-12	1120	91	496	94.3	0.75							1.8	0.6	6	216	9480	10380		
	1250	98		94.3		370	13500	14500											
	1400	110		94.3		420	14200	15200											
	1600	124		94.4		460	14900	15900											
Y800-12	1600	124	497	94.4		0.78	1.8	0.6							6	501	15600	16600	
	1800	139		94.5												610	19150	20350	
	2000	155		94.6												650	19950	21150	
	2240	173		94.7					700	20750	21950								
	2240	173		94.7					760	21550	22750								
Y900-12	2500	190	497	94.8					0.79	1.8	0.6					6	920	23350	24850
	2800	213		94.9													1030	24350	25850
	2800	213		94.9													1120	25350	26850
Y1000-12	3150	239	497	95.0	0.80							1.8	0.6	6			1390	25350	27250
	3550	269		95.1													1510	26750	28650
	4000	303		95.2													1630	28150	30050
	4500	341		95.3													1750	29550	31450
	4500	341		95.3		1887	30950	32850											
	5000	378		95.4		2050	32350	34250											

YKK系列 (6kV) 异步电动机技术数据

型号	额定功率 (kW)	定子电流 (A)	转速 (r/min)	效率 (%)	功率因数 (cosφ)	最大转矩 额定转矩	堵转转矩 额定转矩	堵转电流 额定电流	电机转动 惯量J (kg.m ²)	重量 (kg)
YKK355-4	185	23	1487	92.8	0.85	1.8	6.5	6.5	4	2460
	200	24		92.9					5	2510
	220	27		93.0					6	2560
	250	30		93.1					7	2610
	280	34		93.2	8				2660	
	315	38		93.3	9				2710	
YKK400-4	315	38		93.3	0.86				10	3120
	355	42		93.5					11	3200
	400	48		93.7					13	3280
	450	54		93.9					15	3360
	500	60		94.0					17	3440
	560	67		94.2					19	3520
YKK450-4	560	67	94.2	0.87	21	4350				
	630	75	94.4		23	4460				
	710	84	94.6		26	4570				
	800	93	94.8		30	4680				
	900	105	94.9		35	4790				
YKK500-4	900	105	94.9	0.88	41	5650				
	1000	116	95.0		45	5830				
	1120	130	95.1		49	6010				
	1250	144	95.2		54	6190				
	1400	161	95.3		58	6370				
YKK560-4	1400	161	95.3	0.88	70	7350				
	1600	183	95.4		80	7580				
	1800	206	95.5		90	7810				
	2000	229	95.6		100	8040				
	2240	256	95.7		120	9650				
YKK630-4	2000	229	95.6	0.88	131	10000				
	2240	256	95.7		142	10350				
	2500	285	95.8		144	10700				
	2800	319	95.9							

YKK系列 (6kV) 异步电动机技术数据

型号	额定功率 (kW)	定子电流 (A)	转速 (r/min)	效率 (%)	功率因数 (cosφ)	最大转矩 额定转矩	堵转转矩 额定转矩	堵转电流 额定电流	电机转动 惯量J (kg.m ²)	重量 (kg)		
YKK710-4	2800	319	1492	95.9	0.88	0.5	6.5	6.5	174	14500		
	3150	359		96.0					202	15200		
	3550	404		96.0					216	15900		
	4000	456		96.0					235	16600		
YKK800-4	4500	513		96.0					369	19800		
	5000	569		96.1					408	20600		
	5600	637		96.1					445	21400		
YKK900-4	6300	716		96.2					599	26100		
	7100	806		96.3					739	27100		
	8000	907		96.4					859	28100		
YKK1000-4	9000	1020		1489					96.5	0.89	1029	34200
	10000	1119							96.6		1160	35600
	11200	1252	96.7		1311	37000						
	12500	1396	96.8		1466	38400						
	14000	1562	96.9		1619	39800						
YKK355-6	185	23	986		92.4	0.82	1.8	6	6	7	2660	
	200	25			92.6					8	2710	
	220	28			92.8					9	2760	
	250	32			93.0					10	2810	
	280	35			93.3					14	3180	
YKK400-6	315	40	989		93.5	0.83				15	3260	
	355	44			93.7					17	3340	
	400	49		93.8	19					3420		
	450	55		94.1	21					3500		
	500	61		94.3	24					4240		
YKK450-6	560	68	990	94.4	0.84	27				4350		
	630	76		94.5		30				4460		
	710	86		94.8		33	4570					
	800	97		94.9		36	4680					
	900	107		95.0		41	5410					
YKK500-6	630	76	992	94.5	0.85	44	5590					
	710	86		94.8		48	5770					
	800	97		94.9		52	5950					
	900	107		95.0		56	6130					

YKK系列 (6kV) 异步电动机技术数据

型号	额定功率 (kW)	定子电流 (A)	转速 (r/min)	效率 (%)	功率因数 (cosφ)	最大转矩 额定转矩	堵转转矩 额定转矩	堵转电流 额定电流	电机转动惯量J (kg.m ²)	重量 (kg)								
YKK560-6	1000	119	993	95.1	0.85	1.8	0.7	6.5	89	7620								
	1120	133		95.2					99	7850								
	1250	147		95.3					109	8080								
	1400	164		95.4					119	8310								
YKK630-6	1400	164		95.4	0.86				1.8	0.6	6.5	147	9510					
	1600	187		95.5								168	9860					
	1800	211		95.6								189	10210					
	2000	234		95.7								210	10560					
YKK710-6	2000	234		95.7	0.87							1.8	0.6	6.5	228	14200		
	2240	262		95.7											242	14900		
	2500	292		95.7											270	15600		
	2800	327		95.7											305	16300		
	3150	368	95.8	343		17050												
YKK800-6	3550	415	95.8	0.78	1.8	0.8	6.5	456							21100			
	4000	467	95.9					489							21900			
	4500	525	95.9					521							22700			
YKK900-6	5000	583	96.0	0.79				1.8	0.8	6.5	689				25300			
	5600	645	96.0								735				26300			
	6300	725	96.1								789				27300			
YKK1000-6	7100	816	96.2	0.80							1.8				0.8	6.5	1005	31500
	8000	919	96.3									1230	32900					
	9000	1033	96.4									1467	34300					
	10000	1146	96.5									1699	35700					
YKK400-8	185	25	742	92.5								1.8	0.8	6.5			15	3070
	200	27	92.7	16													3150	
	220	29	92.9	17	3230													
	250	33	93.0	18	3310													
	280	37	93.2	19	3390													
YKK450-8	280	37	739	93.2	1.8	0.8	6.5	28	4090									
	315	41	93.4	31				4200										
	355	46	93.5	33				4310										
	400	51	93.7	36				4420										
	450	58	93.8	39				4530										

YKK系列 (6kV) 异步电动机技术数据

型号	额定功率 (kW)	定子电流 (A)	转速 (r/min)	效率 (%)	功率因数 (cosφ)	最大转矩 额定转矩	堵转转矩 额定转矩	堵转电流 额定电流	电机转动惯量J (kg.m ²)	重量 (kg)											
YKK500-8	450	58	743	93.8	0.80	1.8	0.8	6.5	44	5600											
	500	64		94.2					47	5780											
	560	71		94.4					50	5960											
	YKK560-8	630		78	94.5				0.82	1.8	0.7	6	54	6140							
		710		88	94.6								59	6320							
		710		88	94.6								110	7910							
800		99	94.7	120	8140																
900		109	94.8	129	8370																
1000		121	94.9	139	8600																
YKK630-8	1000	121	745	94.9	0.84				1.8				0.7	6	170	9490					
	1120	135		95.0											190	9840					
	1250	151		95.1											210	10190					
	1400	168		95.2		231	10540														
	1600	193		95.2		252	10890														
	1600	193		95.2		299	13800														
YKK710-8	1800	214	743	95.2	0.85	1.8	0.6	6.5		318	14500										
	2000	238		95.2						339	15200										
	2240	266		95.2						360	15900										
	2500	297		95.3						520	22500										
YKK800-8	2800	332		95.4	0.86					1.8	0.6	6.5			550	23300					
	3150	374		95.4											581	24100					
	3550	421		95.5					630				26800								
YKK900-8	4000	468		745	95.6				0.75				1.8	0.8	5.5	715	27800				
	4500	526			95.7											801	28800				
	5000	584			95.8											1055	31400				
YKK1000-8	5600	654			593				95.8							0.76	1.8	0.8	5.5	1225	32800
	6300	735							95.9											1396	34200
	7100	828	96.0			1578	35600														
	8000	931	96.1			1750	37000														
	185	26	91.7			26	3970														
YKK450-10	200	28	593		91.9	0.75	1.8	0.8	5.5							28				4080	
	220	31			92.1					30	4190										
	250	35			92.3					33	4300										
	280	39			92.5					36	4410										
	315	43		92.8	39					4520											
	355	48		93.0	42					4630											

YKK系列 (6kV) 异步电动机技术数据

型号	额定功率 (kW)	定子电流 (A)	转速 (r/min)	效率 (%)	功率因数 (cosφ)	最大转矩 额定转矩	堵转转矩 额定转矩	堵转电流 额定电流	电机转动 惯量J (kg.m ²)	重量 (kg)								
YKK500-10	355	48	594	93.0	0.76	1.8	0.8	5.5	46	5210								
	400	54		93.3					50	5390								
	450	61		93.4					54	5570								
	500	66		93.6	0.78				58	5750								
	560	74		93.7					62	5930								
	630	83		93.8					66	6110								
YKK560-10	630	83	595	93.8	0.80				0.7	6	110	7360						
	710	93		94.0							119	7590						
	800	102		94.2							130	7820						
YKK630-10	900	115	594	94.3							0.81	0.7	6	149	8050			
	1000	127		94.4										200	9360			
	1120	142		94.6										220	9710			
	1250	157		94.6		242	10060											
YKK710-10	1400	173	596	94.7		0.82	0.6	6						263	10410			
	1600	198		94.8										283	10760			
	1800	223		94.8										344	14500			
	YKK800-10	2000		245										590	94.8	0.83	0.6	6
2240		274	94.9	443											15900			
2500		305	95.0	560	19300													
YKK900-10	2800	341	591	95.1	0.84				0.6	6				645	20100			
	3150	379		95.2										700	20900			
	3550	427		95.3							743	24560						
	4000	480		95.4							850	25560						
YKK1000-10	4500	540	593	95.4							0.84	0.6	6	951	26560			
	5000	600		95.5										1055	27560			
	5600	672		95.5		1496	32150											
	6300	755		95.6		1695	33550											
YKK450-12	185	28	494	91.8		0.70	0.8	5.5						31	4260			
	200	30		92.0										33	4370			
	220	32		92.2										35	4480			
	250	36		92.5										38	4590			

YKK系列 (6kV) 异步电动机技术数据

型号	额定功率 (kW)	定子电流 (A)	转速 (r/min)	效率 (%)	功率因数 (cosφ)	最大转矩 额定转矩	堵转转矩 额定转矩	堵转电流 额定电流	电机转动 惯量J (kg.m ²)	重量 (kg)					
YKK500-12	250	36	494	92.5	0.72	1.8	0.8	5.5	43	5220					
	280	40		92.7					46	5400					
	315	45		92.8					49	5580					
	355	50		93.0	0.74				53	5760					
	400	56		93.3					58	5940					
	450	63		93.4					62	6120					
YKK560-12	450	63	496	93.4	0.76				0.7	6	120	7610			
	500	69		93.7							131	7840			
	560	76		93.8							142	8070			
YKK630-12	630	85	496	93.9							0.77	0.7	6	153	8300
	710	96		94.0										203	9310
	800	108		94.2										222	9660
	900	119		94.2		242	10010								
YKK710-12	1000	133	494	94.2		0.79	0.6	6						268	10360
	1120	145		94.3										285	10710
	1250	161		94.3										323	13900
	1400	181		94.3										344	14600
YKK800-12	1600	204	496	94.3										0.80	0.6
	1800	229		94.4	443				15950						
	2000	255		94.5	580				19500						
	2240	285		94.6	645				20300						
YKK900-12	2500	313	496	94.8	0.81				0.6	6	705	21100			
	2800	351		94.9							860	24950			
	3150	394		95.0							990	25950			
	3550	443		95.1							1110	26950			
YKK1000-12	4000	499	496	95.2		0.81	0.6	6			1496	29120			
	4500	562		95.2							1680	30520			
											1890	31920			
											2123	33320			

YKK系列 (10kV) 异步电动机技术数据

型号	额定功率 (kW)	定子电流 (A)	转速 (r/min)	效率 (%)	功率因数 (cosφ)	最大转矩 额定转矩	堵转转矩 额定转矩	堵转电流 额定电流	电机转动 惯量J (kg.m2)	重量 (kg)									
YKK400-4	185	14	1490	91.7	0.84	1.8	7	7	6	3080									
	200	15		91.9					7	3160									
	220	16		92.1	0.85				8	3240									
	250	18		92.3					9	3320									
	280	21		92.5					10	3400									
	315	23		92.7					11	3480									
	355	26		92.9					12	3560									
YKK450-4	355	26	1492	92.9	0.86				0.7	7	7	15	3970						
	400	29		93.1								17	4080						
	450	32		93.5								19	4190						
	500	36		93.6								20	4300						
	560	40		93.8								22	4410						
YKK500-4	630	45	1489	94.0	0.87							0.6	7	7	24	4520			
	710	50		94.6											39	5330			
	800	56		94.7		42	5510												
	900	62		94.8		45	5690												
	1000	69		94.9		48	5870												
YKK560-4	1120	77	1493	95.0	0.88	0.5	6.5	6.5							51	6050			
	1250	85		95.1											55	6230			
	1400	95		95.3											70	6960			
	1600	109		95.4											73	7190			
YKK630-4	1600	109	1492	95.4	0.89				0.6	6.5	6.5				76	7420			
	1800	122		95.5											80	7650			
	2000	136		95.6											120	9850			
	2240	152		95.7											129	10200			
	2500	169		95.7											140	10550			
YKK710-4	2500	169	1491	95.7	0.89							0.5	6.5	6.5	151	10900			
	2800	190		95.8											162	11250			
	3150	213		95.8											174	14600			
	3550	240		95.8											205	15300			
YKK800-4	3550	240	1493	95.8	0.89										0.5	6.5	6.5	218	16050
	4000	271		95.8		234	16700												
	4500	305		95.8		276	19100												
	5000	338		95.9		305	19900												
YKK900-4	5000	338	1493	95.9	0.89	0.5	6.5	6.5										335	20700
	5600	379		95.9					373	21500									
	6300	426		96.0					545	24300									
	7100	479		96.1					699	25350									
																		819	26350
																		930	27350

YKK系列 (10kV) 异步电动机技术数据

型号	额定功率 (kW)	定子电流 (A)	转速 (r/min)	效率 (%)	功率因数 (cosφ)	最大转矩 额定转矩	堵转转矩 额定转矩	堵转电流 额定电流	电机转动 惯量J (kg.m2)	重量 (kg)						
YKK1000-4	7100	479	1493	96.1	0.89	1.8	6	6	1010	35300						
	8000	539		96.2					1140	36700						
	9000	606		96.3					1281	38100						
	10000	673		96.4					1425	39500						
	11200	753		96.5					1567	40900						
	YKK400-6	185		14					991	91.7	0.81	0.8	6	6	13	3110
200		16	91.9	15	3190											
220		17	92.1	17	3270											
250		19	92.2	19	3350											
YKK450-6	250	19	992	92.2	0.82				0.8	6	6				22	3870
	280	21		92.3											24	3980
	315	24		92.4											27	4090
	355	27		92.7											40	4200
	400	30		92.9											43	4310
YKK500-6	450	34	994	93.1	0.83	0.8	6	6							46	4420
	500	37		93.5											49	5320
	560	41		93.7											52	5500
	630	46		94.0											55	5680
	710	52		94.2											59	5860
YKK560-6	800	58	992	94.3	0.84							0.8	6	6	65	6040
	800	58		94.3											70	6220
	900	65		94.5											82	6910
	1000	72		94.7											92	7140
	1120	80		94.9					103	7370						
YKK630-6	1250	88	993	95.0	0.86				0.7	6.5	6.5				110	7600
	1400	99		95.3											123	7830
	1600	113		95.4											168	9780
	1800	127		95.5											182	10130
	2000	140		95.6		195	10480									
	2000	140		95.6		216	10830									
YKK710-6	2240	157	994	95.6	0.86	0.7	6.5	6.5							239	11180
	2500	176		95.6											285	13700
	2800	197		95.6											318	14400
	2800	197		95.6								343	15100			
YKK800-6	3150	221	994	95.6	0.86							0.7	6.5	6.5	377	15800
	3550	249		95.6											390	20700
	4000	281		95.7											414	21500
															440	22200
															461	23050

YKK系列 (10kV) 异步电动机技术数据

型号	额定功率 (kW)	定子电流 (A)	转速 (r/min)	效率 (%)	功率因数 (cosφ)	最大转矩 额定转矩	堵转转矩 额定转矩	堵转电流 额定电流	电机转动 惯量J (kg.m2)	重量 (kg)
YKK900-6	4000	281	992	95.7	0.86	1.8	0.6	6.5	616	27120
	4500	316		95.7					666	28120
	5000	350		95.8					717	29120
	5600	392		95.8					768	30150
YKK1000-6	5600	392	993	95.8	0.86	1.8	0.6	6.5	861	32260
	6300	441		95.9					987	33660
	7100	497		96.0					1100	35060
	8000	559		96.1					1227	36460
	9000	628		96.2					1372	37860
YKK450-8	185	15	745	91.5	0.76	1.8	0.7	6	24	3720
	200	17		91.7					27	3830
	220	18		91.9					30	3940
	250	21		92.1					32	4050
	280	23		92.3					35	4160
YKK500-8	280	23	745	92.3	0.77	1.8	0.7	6	43	5210
	315	26		92.4					47	5390
	355	29		92.7					51	5570
	400	32		92.8					53	5750
	450	36		93.0					58	5930
YKK500-8	500	39	745	93.4	0.78	1.8	0.7	6	62	6110
	560	44		93.5					66	6290
	560	44		93.5					80	6960
	630	47		94.0					90	7190
	710	53		94.2					100	7420
YKK560-8	800	60	745	94.3	0.82	1.8	0.7	6	110	7650
	900	67		94.4					122	7880
	900	67		94.4					147	9980
	1000	74		94.6					161	10330
YKK630-8	1120	82	743	94.8	0.83	1.8	0.7	6	176	10680
	1250	92		94.9					191	11030
	1400	103		95.0					205	11380
	1400	103		95.0					295	14320
YKK710-8	1600	116	743	95.0	0.84	1.8	0.6	6.5	319	15020
	1800	130		95.0					336	15720
	2000	143		95.0					365	16420
	2000	143		95.0					381	17300
YKK800-8	2240	160	745	95.0	0.85	1.8	0.6	6.5	430	18100
	2500	179		95.0					483	18900
	2500	179		95.0					540	19700
	2800	200		95.1						

YKK系列 (10kV) 异步电动机技术数据

型号	额定功率 (kW)	定子电流 (A)	转速 (r/min)	效率 (%)	功率因数 (cosφ)	最大转矩 额定转矩	堵转转矩 额定转矩	堵转电流 额定电流	电机转动 惯量J (kg.m2)	重量 (kg)
YKK900-8	2800	200	743	95.1	0.85	1.8	0.6	6.5	671	21550
	3150	225		95.2					750	22550
	3550	253		95.3					830	23550
	4000	281		95.4					910	24550
YKK1000-8	4000	281	745	95.4	0.86	1.8	0.6	6.5	1001	26520
	4500	316		95.5					1101	27920
	5000	351		95.6					1215	29320
	5600	393		95.7					1345	30720
	6300	441		95.8					1470	32120
	7100	497		95.9					1599	33520
	1599	497		95.9						
YKK450-10	185	16	593	91.6	0.73	1.8	0.7	5.5	38	4560
	200	17		91.7					41	4670
YKK500-10	220	19	595	91.8	0.74	1.8	0.7	5.5	50	5150
	250	21		91.9					54	5330
	280	24		92.0					58	5510
	315	27		92.2					62	5690
	355	30		92.4					66	5870
YKK560-10	400	33	595	92.6	0.75	1.8	0.7	5.5	71	6050
	400	33		92.6					80	6890
	450	36		92.8					91	7120
	500	40		93.0					102	7350
	560	45		93.1					114	7580
YKK630-10	630	50	596	93.3	0.78	1.8	0.7	6	126	7810
	710	56		93.5					139	8040
	710	56		93.5					168	9590
	800	61		93.9					182	9940
	900	69		94.1					196	10290
YKK710-10	1000	77	596	94.2	0.80	1.8	0.6	6	210	10640
	1120	86		94.3					225	10990
	1250	96		94.4					239	11340
	1250	95		94.5					336	15500
	1400	106		94.5					389	16200
YKK800-10	1600	121	596	94.5	0.81	1.8	0.6	6	443	16900
	1600	121		94.5					556	18950
	1800	134		94.5					620	19750
	2000	149		94.5					692	20550
YKK900-10	2240	167	596	94.6	0.82	1.8	0.6	6	750	21350
	2240	167		94.6					791	23200
	2500	186		94.7					861	24600
	2800	208		94.8					929	26000
	2800	208		94.8					981	27400
	3150	231		94.9						
	3150	231		94.9						

九、外形尺寸

YKK系列 (10kV) 异步电动机技术数据

型号	额定功率 (kW)	定子电流 (A)	转速 (r/min)	效率 (%)	功率因数 (cosφ)	最大转矩 额定转矩	堵转转矩 额定转矩	堵转电流 额定电流	电机转动惯量J (kg.m ²)	重量 (kg)
YKK1000-10	3150	231	596	94.9	0.83	1.8	6	0.6	1040	32100
	3550	260		95.0					1217	33500
	4000	293		95.1					1383	34900
	4500	329		95.2					1566	36300
	5000	365		95.3					1729	37700
	5600	408		95.5					1862	39100
	YKK500-12	185		17					496	91.1
200		18	91.3	59	4530					
220		20	91.5	66	4710					
280		24	91.7	72	4890					
280		24	91.7	90	6490					
YKK560-12	315	27	496	91.9	0.72	1.8	6	0.7	100	6720
	355	30		92.1					110	6950
	400	34		92.3					120	7180
	450	38		92.5					130	7410
	500	43		92.8					140	7640
	500	43		92.8					174	9570
YKK630-12	560	47	494	93.1	0.73	1.8	6	0.6	188	9920
	630	53		93.3					201	10270
	710	59		93.5					216	10620
	800	66		93.9					230	10970
	900	75		93.9					245	11320
YKK710-12	900	72	494	93.9	0.74	1.8	6	0.6	362	13400
	1000	80		94.0					383	14100
	1120	89		94.0					404	14800
	1250	100		94.0					425	15500
YKK800-12	1250	98	496	94.1	0.77	1.8	6	0.6	591	18300
	1400	110		94.1					645	19100
	1600	124		94.1					696	19900
YKK900-12	1800	140	490	94.1	0.79	1.8	6	0.6	751	20700
	1800	140		94.1					834	22560
	2000	155		94.2					940	23560
YKK1000-12	2240	174	490	94.3	0.80	1.8	6	0.6	1039	24560
	2240	174		94.3					1169	26900
	2500	191		94.4					1301	28300
	2800	214		94.5					1452	29700
	3150	240		94.6					1605	31100
	3550	271		94.7					1766	32550
	4000	305		94.8					1930	33950

Y系列 (6kV) 中型高压三相异步电动机外形尺寸图

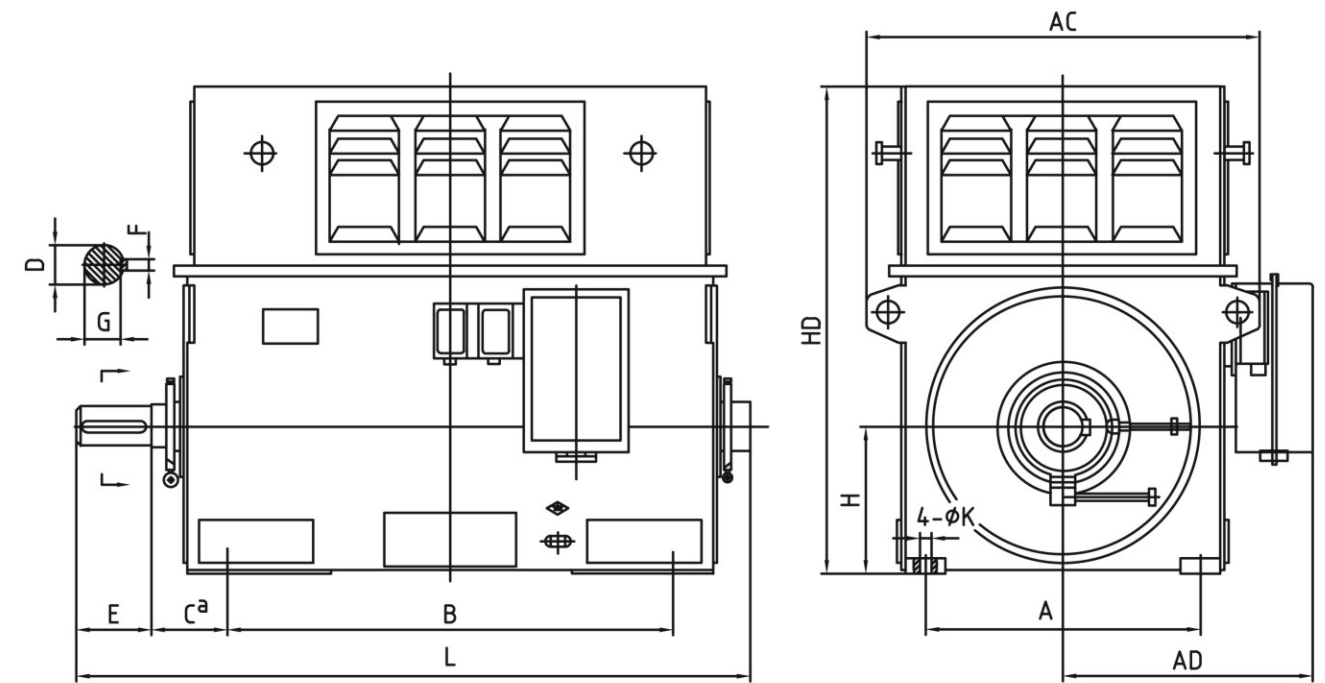

机座号	极数	安装尺寸及公差														外形尺寸 (参考值)							
		A		B		C*		D		E		F		G		H		K		AC	AD	HD	L
		基本尺寸	极限偏差	基本尺寸	极限偏差	基本尺寸	极限偏差	基本尺寸	极限偏差	基本尺寸	极限偏差	基本尺寸	极限偏差	基本尺寸	极限偏差	基本尺寸	极限偏差	基本尺寸	极限偏差				
355	4-6	630	±1.4	900	±1.4	315		100	+0.035	210		28	0	90		355		28	+0.52 0	1100	800	1170	1890
400	4-8	710		1000		335		110	-0.013	210		28	-0.052	100	0	400		35		1150	850	1330	1980
450	4	800	±1.75	1120	±1.75	475	±4.0	120		250	±0.57	32		109	-0.2	450		0		1300	900	1475	2180
	6-12							130					119		500		0		1300	900	1475	2180	
500	4	900		1250		500		130		250		36	0	128		560		-1.0		1420	955	1655	2550
	6-12							140					128		560		0		1420	955	1655	2550	
560	4	1000	±2.10	1400	±2.10	500		150	+0.040	300	±0.65	40	-0.062	138		630		0		1600	1100	1850	2900
	6-12							160						147		630		-0.3		1600	1100	1850	2900
630	4	1120		1600		530		170		300	±0.65	45		157		630		0		1800	1200	2050	3100
	6-12							180						165		630		0		1800	1200	2050	3100

注：a 当采用滑动轴承时，极限偏差不包括轴向窜动量。

Y系列 (10kV) 中型高压三相异步电动机外形尺寸图

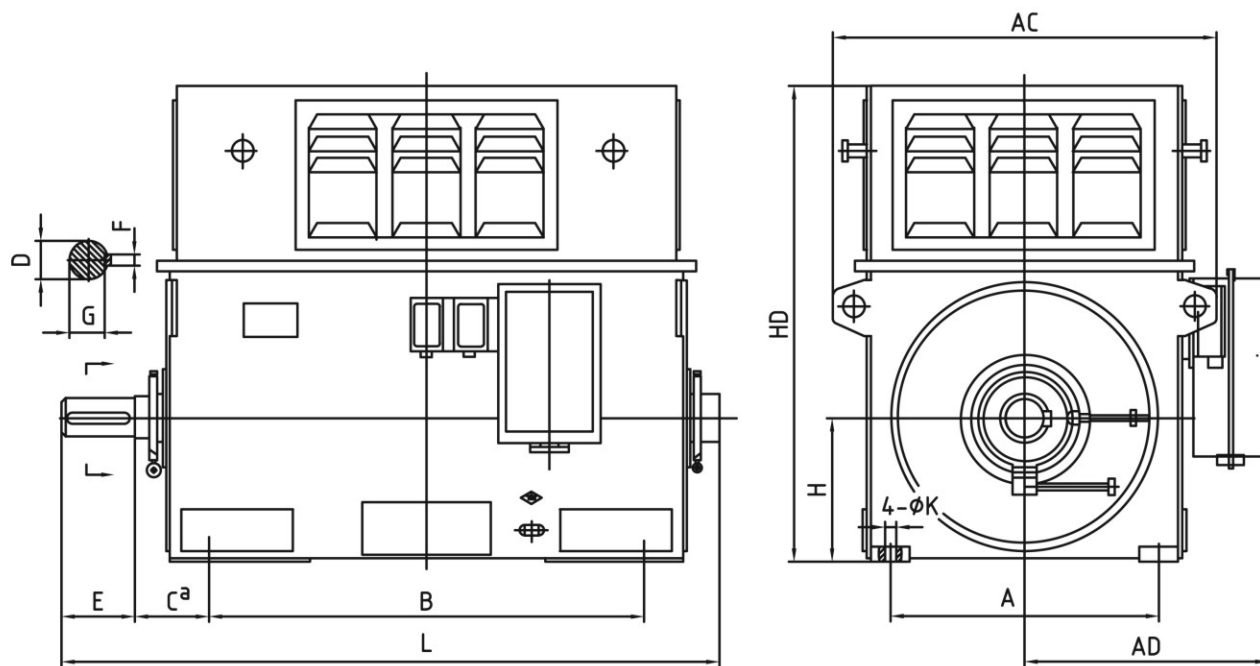

YKS系列 (6kV) 中型高压三相异步电动机外形尺寸图

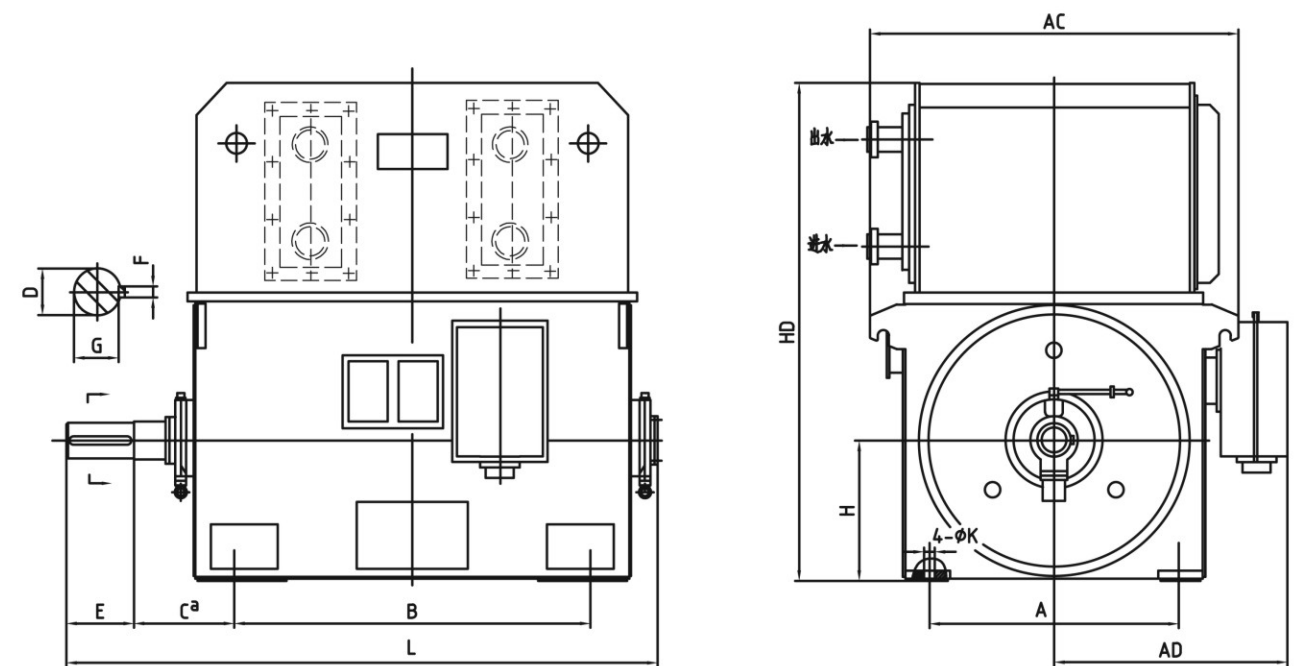

机座号	极数	安装尺寸及公差																外形尺寸 (参考值)						
		A		B		C ^a		D		E		F		G		H		K		AC	AD	HD	L	
		基本尺寸	尺寸偏差	基本尺寸	尺寸偏差	基本尺寸	尺寸偏差	基本尺寸	尺寸偏差	基本尺寸	尺寸偏差	基本尺寸	尺寸偏差	基本尺寸	尺寸偏差	基本尺寸	尺寸偏差	基本尺寸	尺寸偏差					
400	4-6	710		1000																1100	800	1170	1890	
450	4	800	±1.75	1120	±1.75	355	110	+0.035	210	28	0	100	0	450	35									
	6																							
500	4	900		1250		475	±4.0	120				109	500	0	42	+0.62								
	6-10							130				119		-1.0										
560	4	1000	±2.10	1400	±2.10	500		150	+0.040			138	560	0										
	6-12							160				147		0										
630	4	1120		1600		530		170	-0.015			157	630	-0.3										
	6-12							180				165		0										

注：a 当采用滑动轴承时，极限偏差不包括轴向窜动量。

机座号	极数	安装尺寸及公差																外形尺寸 (参考值)					
		A		B		C ^a		D		E		F		G		H		K		AC	AD	HD	L
		基本尺寸	极限偏差	基本尺寸	极限偏差	基本尺寸	极限偏差	基本尺寸	极限偏差	基本尺寸	极限偏差	基本尺寸	极限偏差	基本尺寸	极限偏差	基本尺寸	极限偏差	基本尺寸	极限偏差				
355	4-6	630	±1.4	900	±1.4	315		100	+0.035	210	28	0	90		355		28	+0.52	1100	800	1370	1890	
400	4-8	710		1000		335		110	-0.013			109	0	400									
	4							±1.75				±1.75											
450	4	800	±1.75	1120	±1.75	475	±4.0	120				109	500	0	42	+0.62							
	6-12							130				119		-1.0									
500	4	900		1250		475	±4.0	130				130	500	0	42	+0.62							
	6-12							140				128		0									
560	4	1000	±2.10	1400	±2.10	500		150	+0.040			138	560	0									
	6-12							160				147		0									
630	4	1120		1600		530		170	-0.015			157	630	-0.3									
	6-12							180				165		0									

注：a 当采用滑动轴承时，极限偏差不包括轴向窜动量。

YKK系列 (10kV) 中型高压三相异步电动机外形尺寸图

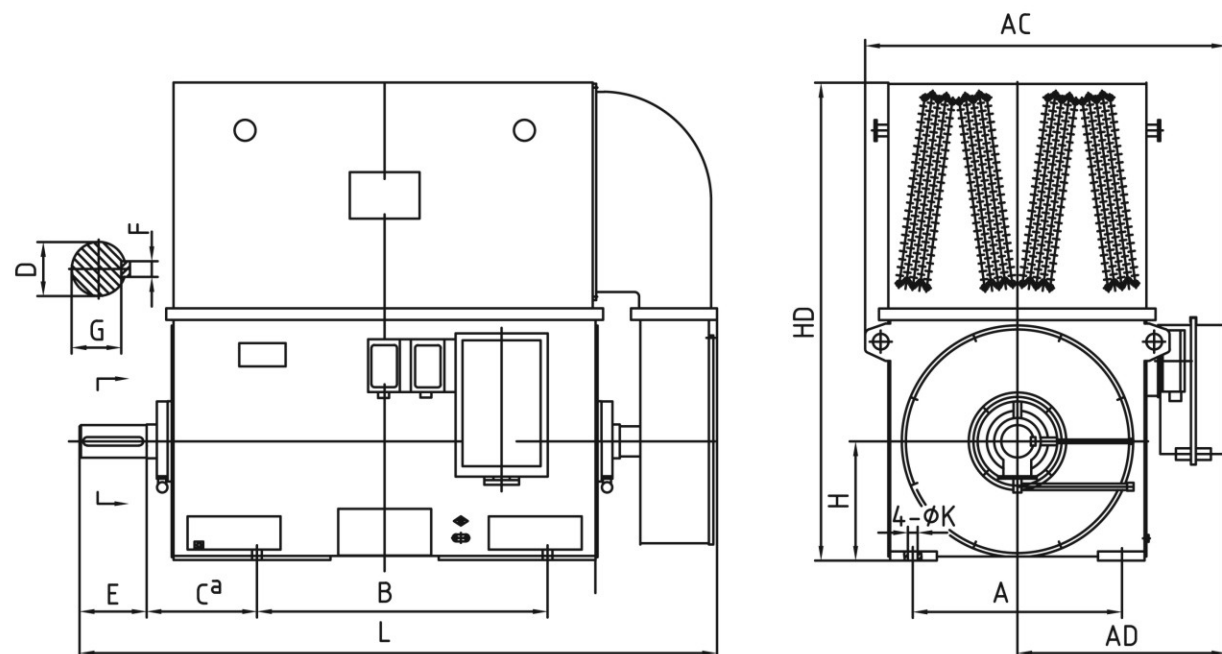

Y系列大型高压三相异步电动机外形尺寸图

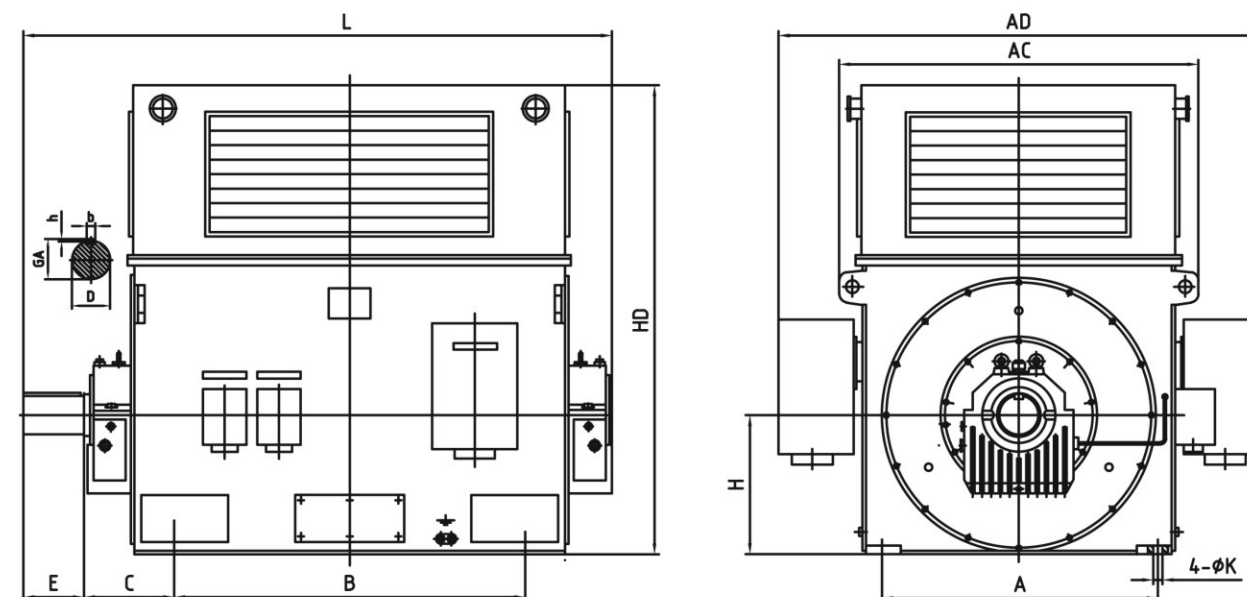

机座号	极数	安装尺寸及公差																外形尺寸 (参考值)					
		A		B		C ^a		D		E		F		G		H		K		AC	AD	HD	L
		基本尺寸	尺寸偏差	基本尺寸	尺寸偏差	基本尺寸	尺寸偏差	基本尺寸	尺寸偏差	基本尺寸	尺寸偏差	基本尺寸	尺寸偏差	基本尺寸	尺寸偏差	基本尺寸	尺寸偏差	基本尺寸	尺寸偏差				
400	4-6	710		1000							0				400				1260	1050	1700	2400	
450	4	±1.75	800	±1.75	355	110	+0.035	210	28	0	100	0	450	35	530	0	450	35	1300	1050	1850	2600	
	6-10																						
500	4	±2.10	900	±2.10	500	120	+0.040	250	32	0	109	-0.2	500	0	600	0	560	-10	1420	1110	2000	3000	
	6-10																						
560	4	±2.10	1000	±2.10	500	150	+0.040	300	36	0	138	-0.062	560	42	630	0	630	-10	1600	1200	2150	3400	
	6-12																						
630	4	±2.10	1120	±2.10	530	170	+0.015	300	40	0	157	-0.062	630	48	630	0	630	-10	1800	1300	2350	3600	
	6-12																						

注：a 当采用滑动轴承时，极限偏差不包括轴向窜动量。

机座号	极数	安装尺寸及公差														外形尺寸 (参考值)						
		A		B		C ^a		D		E		b	h	GA	H	K	AC	AD	HD	L		
		基本尺寸	尺寸偏差	基本尺寸	尺寸偏差	基本尺寸	尺寸偏差	基本尺寸	尺寸偏差	基本尺寸	尺寸偏差	基本尺寸	基本尺寸	基本尺寸	基本尺寸	基本尺寸						
710	4极以上	1400		1800				200				45	25	210	710				2000	2540	2650	3350
800	4极以上	±2.8	1600	±2.8	2000	530	0	220	+0.046	±0.7	350	50	28	231	800	56	2200	2740	2900	3600		
900	4极以上	±2.8	1800	±2.8	2240	600	0	250	+0.052	±0.77	410	56	32	262	900	0	1420	1110	2000	3000		
1000	4极以上	±3.5	2000	±3.5	2500	630	0	280	+0.020	±0.77	470	63	32	292	1000	-15	1600	1200	2150	3400		
1120	4极以上	±3.5	2240	±3.5	2800	630	0	320	+0.021	±0.77	470	70	36	334	1120	-15	1800	1300	2350	3600		

注：a 当采用滑动轴承时，极限偏差不包括轴向窜动量。

YKS系列大型高压三相异步电动机外形尺寸图

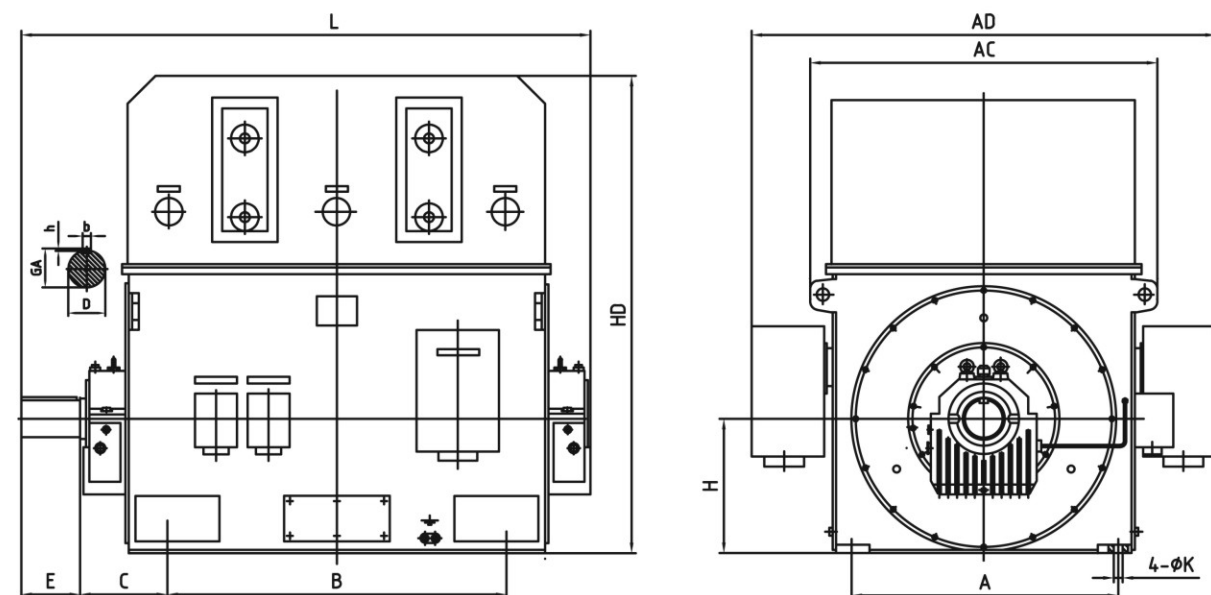

YKK系列大型高压三相异步电动机外形尺寸图

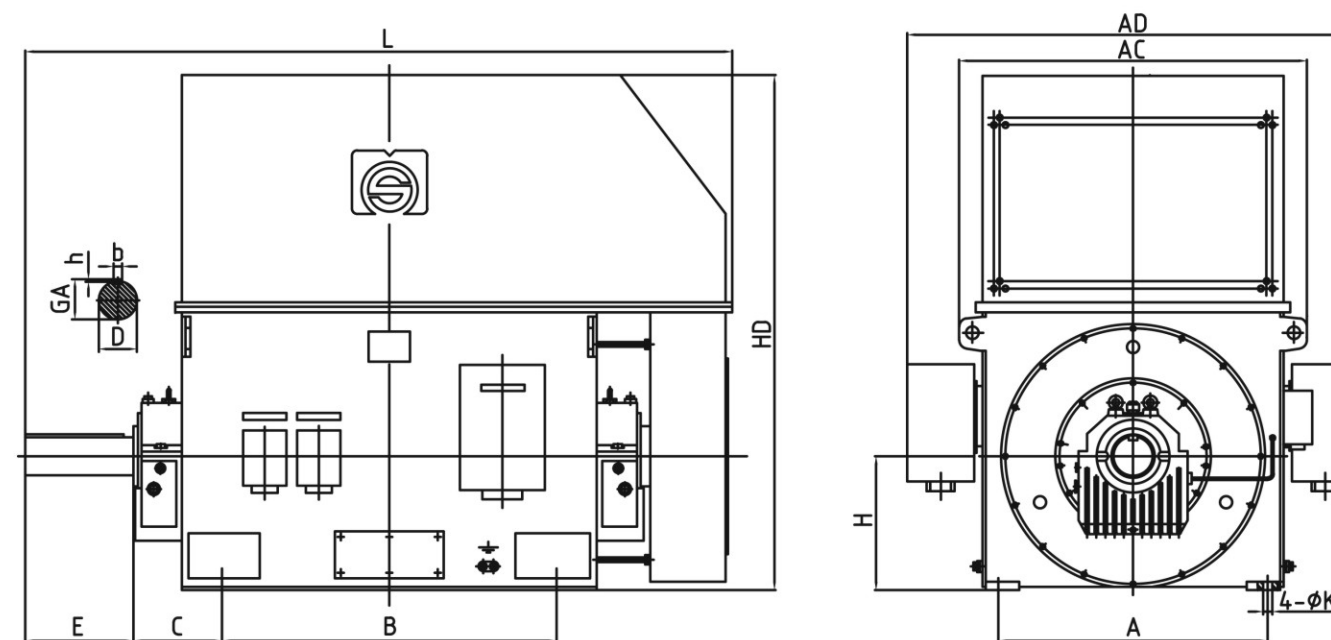

机座号	极数	安装尺寸及公差														外形尺寸(参考值)				
		A		B		C ^a		D		E		b	h	GA	H	K	AC	AD	HD	L
		基本尺寸	极限偏差	基本尺寸	极限偏差	基本尺寸	极限偏差	基本尺寸	极限偏差	基本尺寸	极限偏差	基本尺寸	基本尺寸	基本尺寸	基本尺寸	极限偏差				
710	4极以上	1400		1800				200				45	25	210	710		2000	2540	2650	3350
			±2.8		±2.8	530				350	±0.7					56				
800	4极以上	1600		2000			220	+0.046 +0.017				50	28	231	800		2200	2740	2950	3600
900	4极以上	1800		2240			250		410			56		262	900	0 -15	2400	2940	3250	3900
						600							32							
1000	4极以上	2000	±3.5	2500	±3.5		280	+0.052 +0.020		±0.77		63		292	1000		2650	3190	3600	4300
1120	4极以上	2240		2800		630	320	+0.057 +0.021				70	36	334	1120		2900	3440	4100	4600

注：a 当采用滑动轴承时，极限偏差不包括轴向窜动量。

机座号	极数	安装尺寸及公差														外形尺寸(参考值)				
		A		B		C ^a		D		E		b	h	GA	H	K	AC	AD	HD	L
		基本尺寸	极限偏差	基本尺寸	极限偏差	基本尺寸	极限偏差	基本尺寸	极限偏差	基本尺寸	极限偏差	基本尺寸	基本尺寸	基本尺寸	基本尺寸	极限偏差				
710	4极以上	1400		1800				200				45	25	210	710		2000	2540	2900	4100
			±2.8		±2.8	530										56				
800	4极以上	1600		2000			220	+0.046 +0.017				50	28	231	800		2200	2740	3200	4500
900	4极以上	1800		2240			250		410			56		262	900	0 -15	2400	2940	3500	4900
						600							32							
1000	4极以上	2000	±3.5	2500	±3.5		280	+0.052 +0.020		±0.77		63		292	1000		2650	3190	3800	5300
1120	4极以上	2240		2800		630	320	+0.057 +0.021				70	36	334	1120		2900	3440	4250	5700

注：a 当采用滑动轴承时，极限偏差不包括轴向窜动量。